

LARGE CAPACITY TRAY
(Machine Code: B600)

1. REPLACEMENT AND ADJUSTMENT

1.1 DETACHING THE TRAY FROM THE MAINFRAME

1. To draw the tray out, press the stopper [A] on the guide rail.
2. To install the tray, set the tray on the guide rails, keep the tray level, and push the tray in.

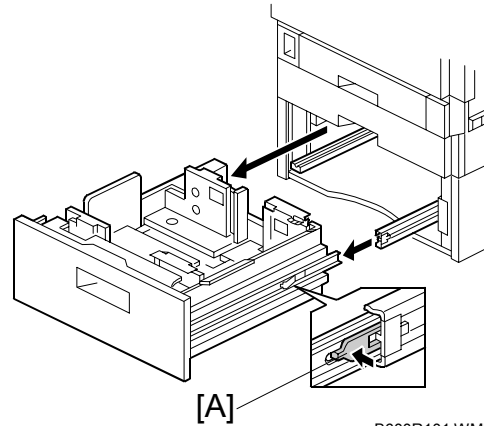

B600R101.WMF

1.2 REAR FENCE HP SENSOR

1. Pull out the large capacity tray.
2. Left tray rear side fence [A] (⚙ x 2)
3. Rear fence bracket [B] (⚙ x 1)
4. Connector of the rear fence HP sensor [C]
5. Rear fence HP sensor [D] (⚙ x 1)

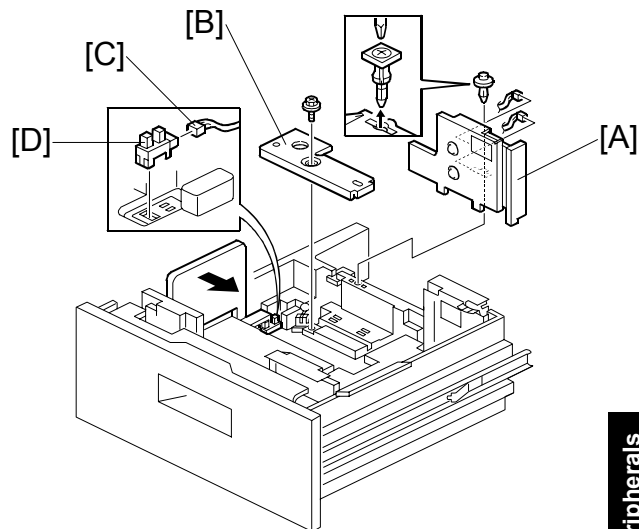

B600R102.WMF

1.3 CHANGING THE TRAY PAPER SIZE

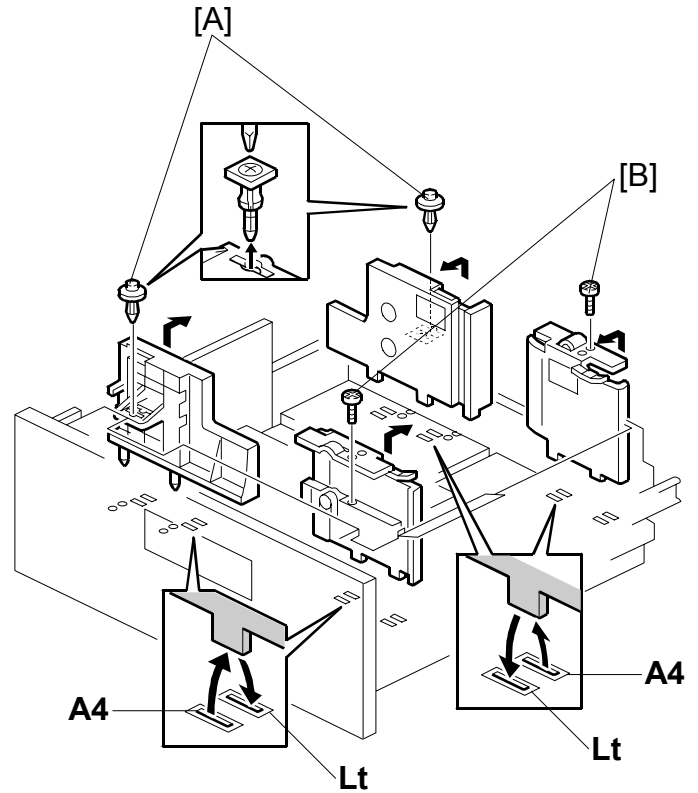

1. Screws [A] [B]
2. Change the position of the side fences.
3. Change the position of the rear fence HP sensor (☛ 1.2).
4. Before securing the right tray side fence, load the paper in the right tray, and adjust the fence.

1.4 LEFT TRAY PAPER END SENSOR

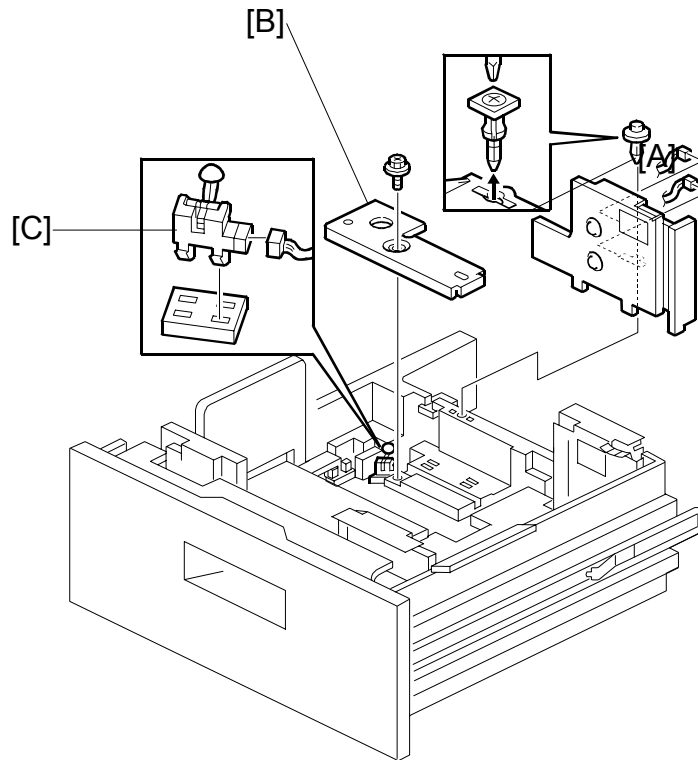

B600R104.WMF

1. Pull out the large capacity tray.
2. Left tray side fence [A] (⌘ x 2)
3. Rear fence bracket [B] (⌘ x1)
4. Left tray paper end sensor [C] (⌘ x 1)

1.5 TRAY LIFT MOTOR

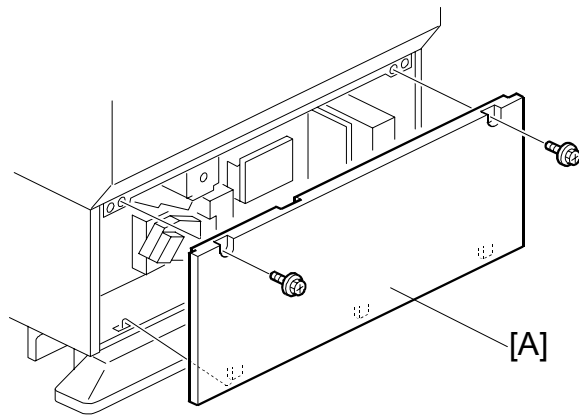

B600R105.WMF

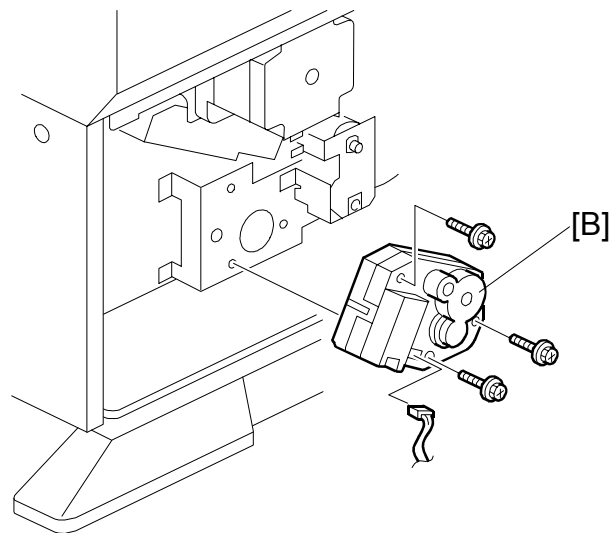

B600R106.WMF

1. Rear cover [A] (🔩 x 2)
2. Tray lift motor [B] (🔩 x 3, 🌂 x 1)

1.6 TRAY MOTOR AND STACK TRANSPORT CLUTCH

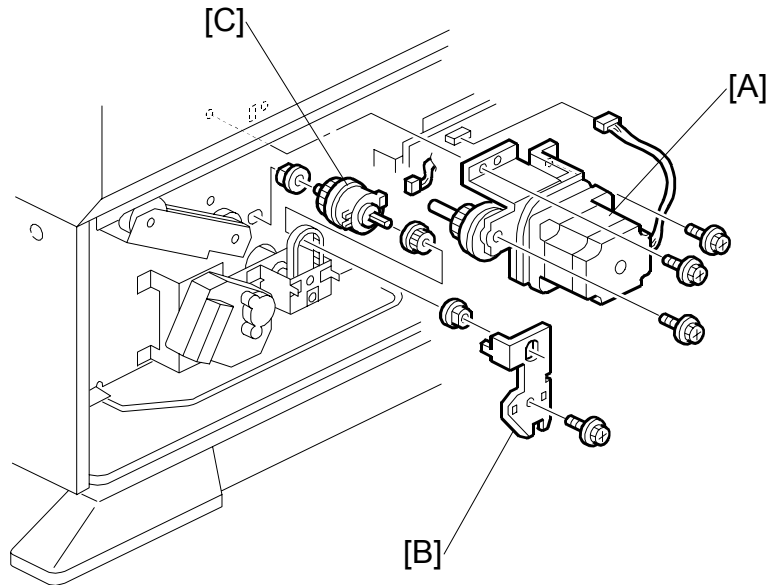

B600R107.WMF

1. Rear cover (☛ 1.5)
2. Tray motor [A] (☛ x 6, ☛ x 1)
3. Bracket [B] (☛ x 1)
4. Stack transport clutch [C] (☛ x 2, 2 bushings, 1 gear)

1.7 PAPER FEED CLUTCH

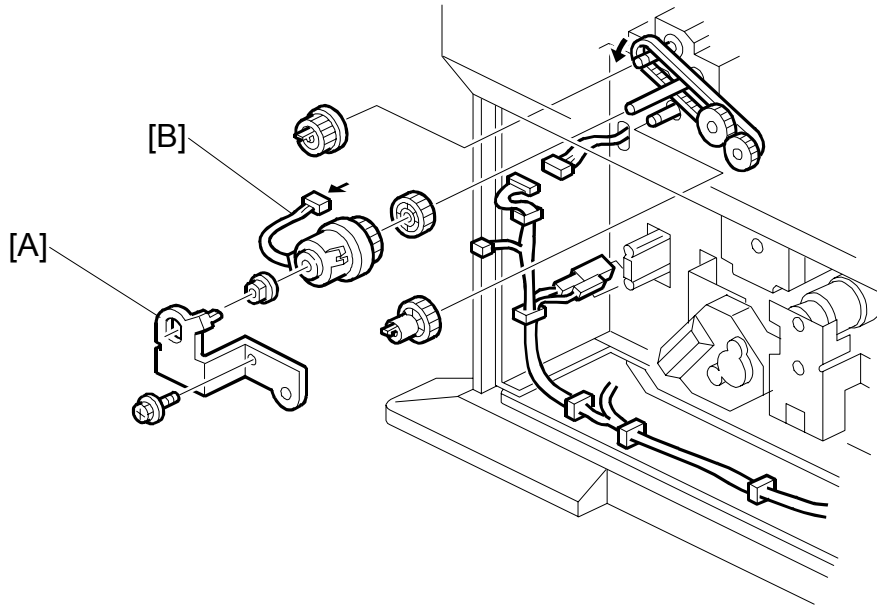

B600R108.WMF

1. Rear cover (🔩 1.5)
2. Bracket [A] (🔩 x 1)
3. Bushing
4. Paper feed clutch [B]

1.8 PAPER FEED UNIT

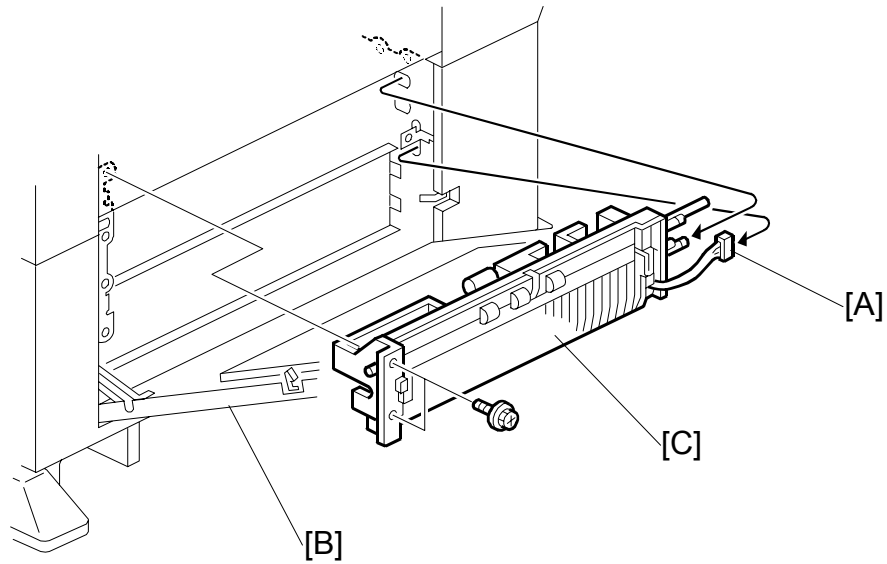

B600R109.WMF

1. Stack transport clutch (☛ 1.6)
2. Paper feed clutch (☛ 1.7)
3. Paper feed unit cable [A]
4. Open the vertical transport guide plate [B].
5. Paper feed unit [C] (☛ x 2)

1.9 UPPER LIMIT, RIGHT TRAY PAPER END, AND RELAY SENSORS

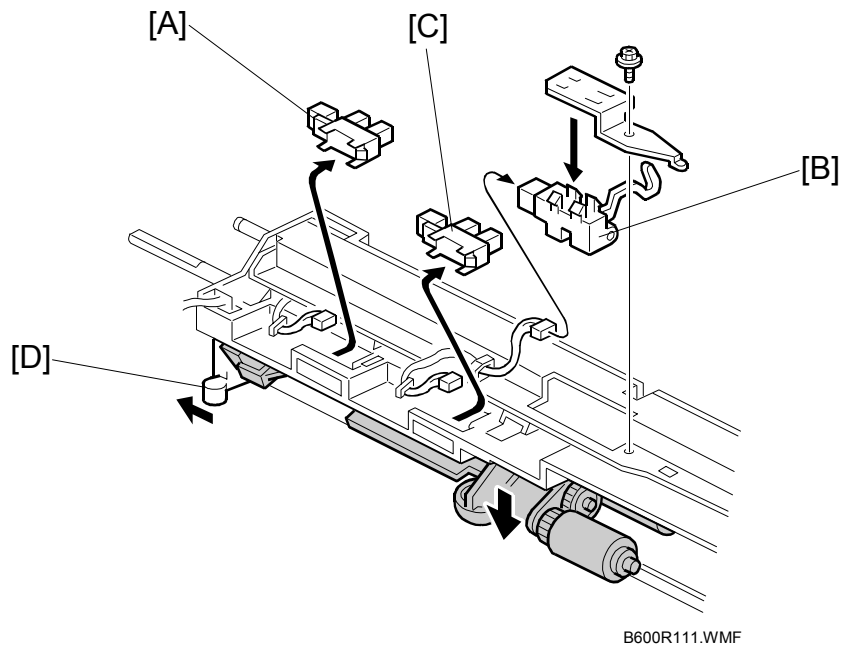

1. Paper feed unit (☛ 1.8)
2. Sensors
 - Upper limit [A]
 - Relay [B] (⚙ x 1, 1 bracket)
 - Right tray paper end [C]

NOTE: To remove the upper limit [A] or paper end sensor[C], press the lever [D] and hold it down.

1.10 PICK-UP/PAPER FEED/SEPARATION ROLLER

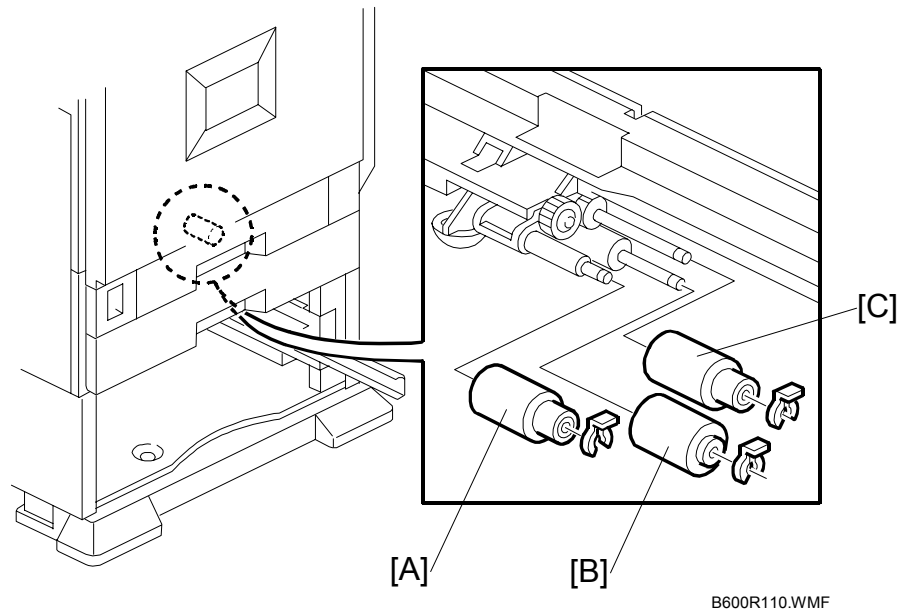

1. Paper tray unit
2. Pick-up roller [A] (1 hook)
3. Separation roller [B] (2 x 1)
4. Feed roller [C] (1 x 1)

NOTE: If the rollers are incorrectly installed, the one-way clutch does not work.

2. DETAILED SECTION DESCRIPTIONS

2.1 OVERVIEW

2.1.1 MECHANICAL COMPONENT LAYOUT

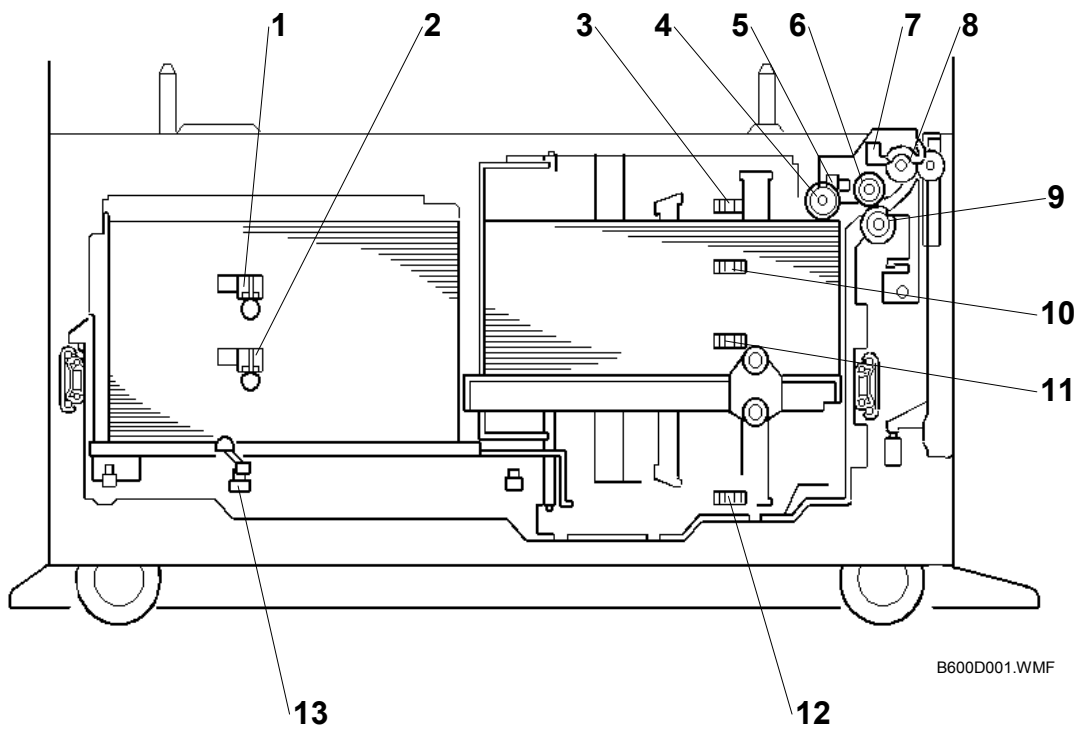

- | | |
|---------------------------|----------------------------|
| 1. Paper Height Sensors 5 | 8. Relay Roller |
| 2. Paper Height Sensors 4 | 9. Separation Roller |
| 3. Paper Height Sensors 1 | 10. Paper Height Sensors 2 |
| 4. Pick-up Roller | 11. Paper Height Sensors 3 |
| 5. Upper Limit Sensor | 12. Lower Limit Sensor |
| 6. Paper Feed Roller | 13. Left Paper End Sensor |
| 7. Relay Sensor | |

2.1.2 ELECTRICAL COMPONENT LAYOUT

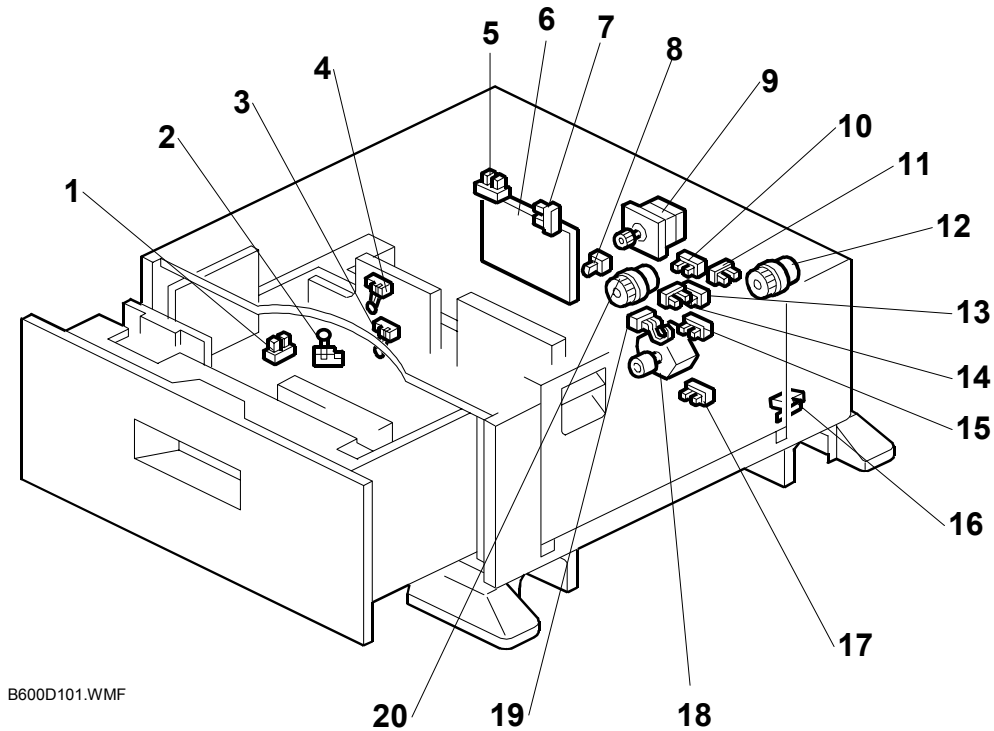

- | | |
|-----------------------------------|---------------------------------|
| 1. End Fence Home Position Sensor | 11. Upper Limit Sensor |
| 2. Left Tray Paper End Sensor | 12. Paper Feed Clutch |
| 3. Paper Height Sensor 4 | 13. Paper Height Sensor 2 |
| 4. Paper Height Sensor 5 | 14. Right Tray Paper End Sensor |
| 5. Paper Size Sensor | 15. Paper Height Sensor 3 |
| 6. Main Board | 16. Vertical Guide Switch |
| 7. Side Fence Open/Closed Sensor | 17. Lower Limit Sensor |
| 8. Tray Sensor | 18. Tray Lift Motor |
| 9. Tray Motor | 19. Relay Sensor |
| 10. Paper Height Sensors 1 | 20. Stack Transport Clutch |

2.2 PAPER FEED

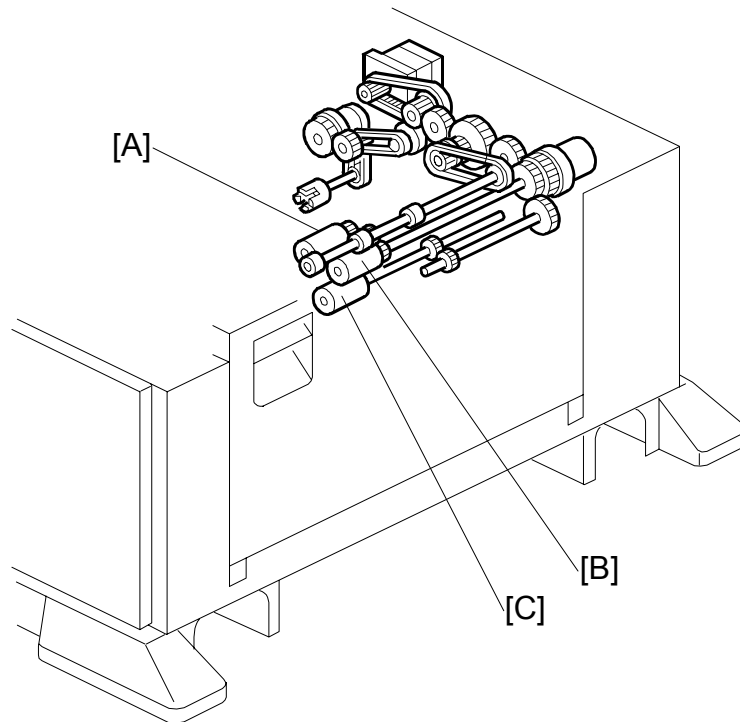

B600D102.WMF

- This product uses an FRR type paper feed mechanism.
- The paper feed unit consists of the pick-up roller [A], paper feed roller [B], separation roller [C], and relay roller.
- There is a torque limiter (ferrite powder type) in the back of the separation roller.

2.3 SEPARATION ROLLER AND PICK-UP ROLLER RELEASE

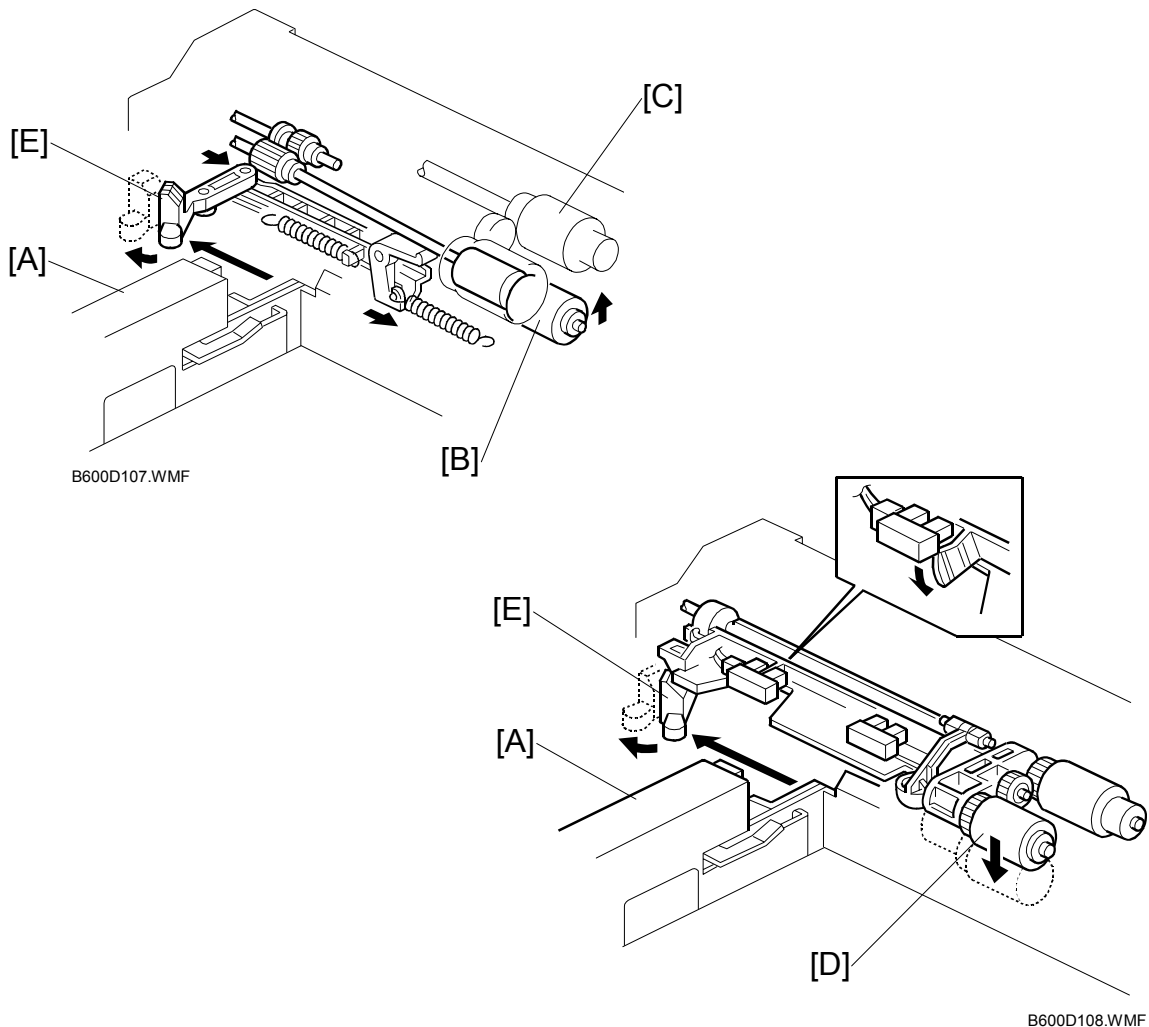

To prevent the paper from being torn when pulling out the paper feed tray, the separation and pickup rollers are set so that they release automatically.

When the paper tray [A] is not inside the machine, the separation roller [B] is away from the paper feed roller [C] and the pick-up roller [D] stays in the upper position.

When the paper tray is set into the machine, it pushes the release lever [E]. This causes the pick-up roller to go down into contact with the top sheet of paper and the separation roller to move up and contact the paper feed roller.

2.4 TRAY LIFT

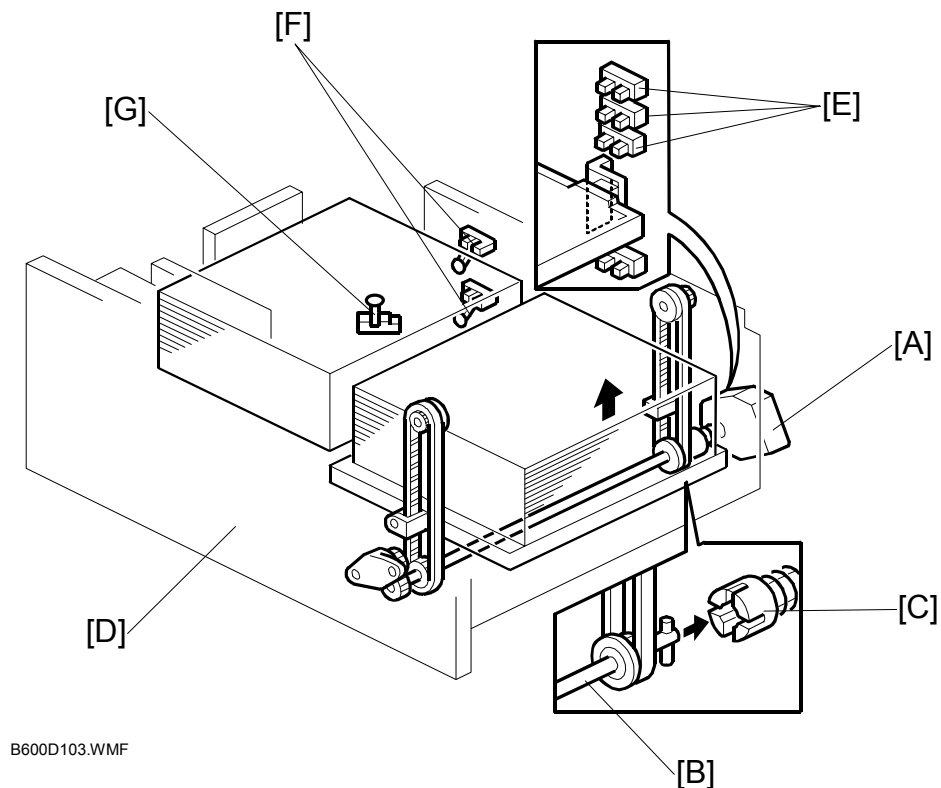

B600D103.WMF

When the paper feed tray is put in the machine, the tray sensor on the back face turns on and the tray lift motor [A] starts. The base plate lift shaft [B] is coupled to the lift motor at shaft [C], so the base plate of the tray is lifted. After a short while, the top of the paper stack contacts the pick-up roller and lifts it up.

When this occurs, the actuator enters the upper limit sensor, the sensor turns off and the lift motor stops. When paper in the tray is used up, the pick-up roller is gradually lowered, and the actuator leaves the upper limit sensor (turning the sensor on). When this happens, the lift motor begins turning again. The tray will then be lifted until the actuator enters the upper limit sensor (turning the sensor off again).

When the tray is removed from the printer, the coupling between the lift motor and base plate lift shaft is broken and the base plate goes into a controlled free fall (using a damper [D] to slow the fall and prevent damage).

2.5 NEAR END/END DETECTION

This tray holds two stacks of paper, so the machine needs to monitor the status of both these stacks. There are seven sensors to do this.

In the right tray (paper feed side), three height sensors ([E] in the diagram on the previous page) measure the height of the stack, and an end sensor detects when all the paper is used up. As the amount of paper remaining in the tray decreases, the base plate rises and the actuator activates the paper height sensors. When paper runs out in the right tray, the stack in the left tray is moved across to the right tray.

There are also two height sensors ([F] in the diagram on the previous page) and an end sensor in the left tray (paper storage side) ([G] in the diagram on the previous page). When there is no paper in both trays, paper end is detected.

The machine determines the amount of remaining paper based on the sensor outputs, as shown in the following table.

	Amount of paper								
	100%	75%	50%						
Paper Height Sensor 1	○	○	○	○	○	○	●	○	○
Paper Height Sensor 2	○	○	○	○	○	●	-	○	●
Paper Height Sensor 3	○	○	●	○	○	-	-	●	-
Right Tray Paper End Sensor	●	●	●	●	●	●	●	●	●
Paper Height Sensor 4	○	○	○	●	●	○	○	○	○
Paper Height Sensor 5	○	●	○	●	●	○	○	●	●
Left Tray Paper End Sensor	○	○	○	○	●	○	○	○	○

	Amount of paper							
	25%				Near-end		End	
Paper Height Sensor 1	●	○	○	○	○	●	●	-
Paper Height Sensor 2	-	○	●	○	●	-	-	-
Paper Height Sensor 3	-	●	-	●	-	-	-	-
Right Tray Paper End Sensor	●	●	●	●	●	●	●	○
Paper Height Sensor 4	○	●	●	●	●	●	●	●
Paper Height Sensor 5	●	●	●	●	●	●	●	●
Left Tray Paper End Sensor	○	○	○	●	●	○	●	●

Right tray paper end sensor: ○ = Low (no paper), ● = High (paper present)
 Other sensors: ○ = Low (paper present), ● = High (no paper)

The following diagram is the sensor layout, as viewed from the front.

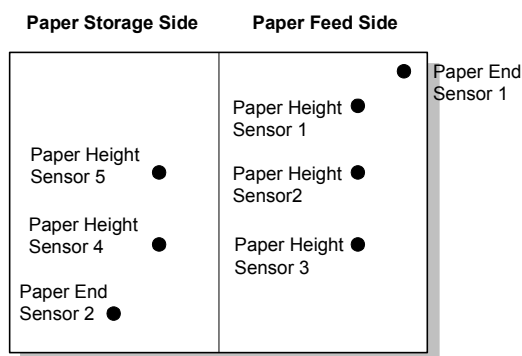

2.6 PAPER STACK TRANSPORT MECHANISM

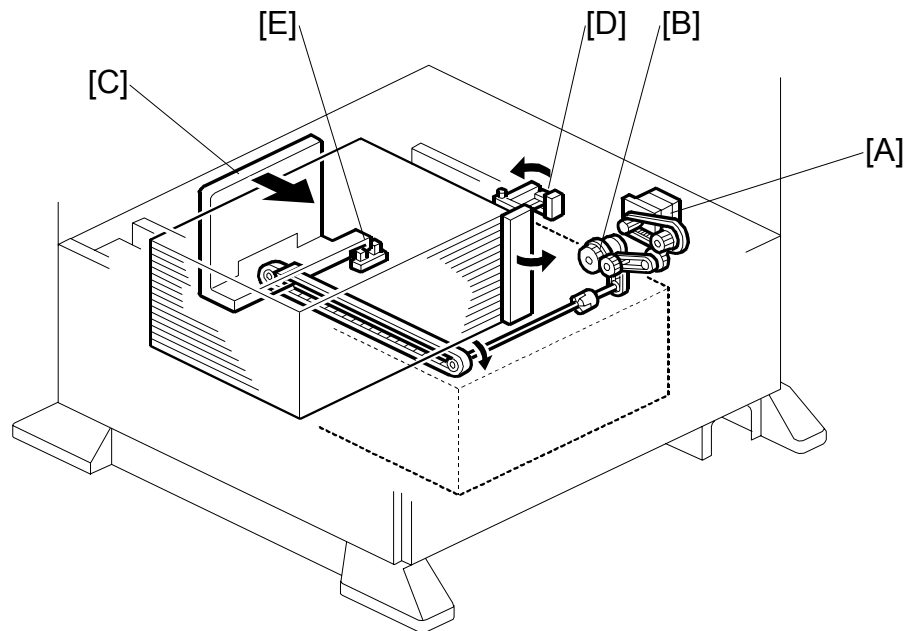

B600D104.WMF

When the paper in the right tray is used up, the tray motor [A] and stack transport clutch [B] turn on. Then the rear fence [C] moves the stack of paper from the left tray to the right tray.

While the stack is being moved, it pushes the side fence aside, and the side fence open/closed sensor [D] detects that the fence is open.

After the stack has been moved across, a spring in the side fence moves the side fence back, and the sensor detects that the fence is closed. Then, the tray motor reverses until end fence home position sensor [E] is deactivated.

2.7 RIGHT TRAY PAPER END DETECTION

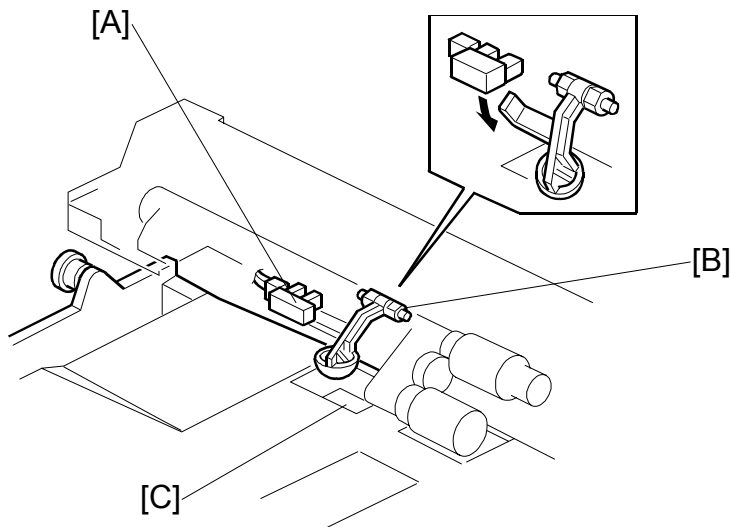

B600D106.WMF

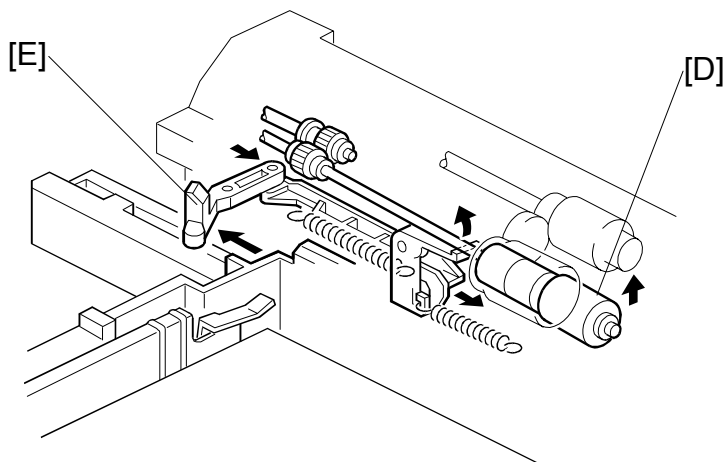

B600D111.WMF

The paper end sensor [A] detects when copy paper in the right tray runs out.

When there is paper in the tray, the paper pushes up the paper end feeler [B] and causes the actuator to enter the sensor. When paper runs out, the feeler drops and the actuator leaves the sensor, and the machine detects that there is no paper in the tray.

When the tray is being pulled out, the lever [E] lifts the pick-up roller and this also lifts up the feeler.